

WOODEN AND ALUMINUM CLAD WINDOW INSTALLATION GUIDE

Wooden and aluminum clad window installation guide

- Before lifting the window into the opening, remove the frames and attach the wall anchors to the sash. The wall anchors should be fastened with 5 x 40 mm screws at intervals of 100-200 mm from the corner and longitudinally, after every 700 mm.
- Then lift the sashes into the opening and install wedges between the lower horizontal and the wall (Pos 6). The thickness of the wedges must be chosen so that the distance between the upper horizontal and the wall is min 5 mm and max 20 mm.
- Level the lower horizontal (Pos A).
- After that, install wedges between the verticals and the wall (Pos 5) and level the verticals in each direction, i.e. from the inside and edge surfaces of the sash (Pos B).
- Attach the wall anchors to the wall (Assembly 1). In the case of a stone wall, drill wall plug holes for installing wall plugs for the screws by screw holes in the wall anchor.
- After mounting the sashes, place the frames in the sashes.
- Fill the gap between the sashes and the wall with filling material (e.g. mounting foam, mineral wool, etc.). If necessary, install an intermediate support during filling to prevent the bending of the sashes.

If the window is not operating or is not operating properly, use the hex key to adjust the frame from the lower or upper hinge.

The assemblies and details shown in the figure.

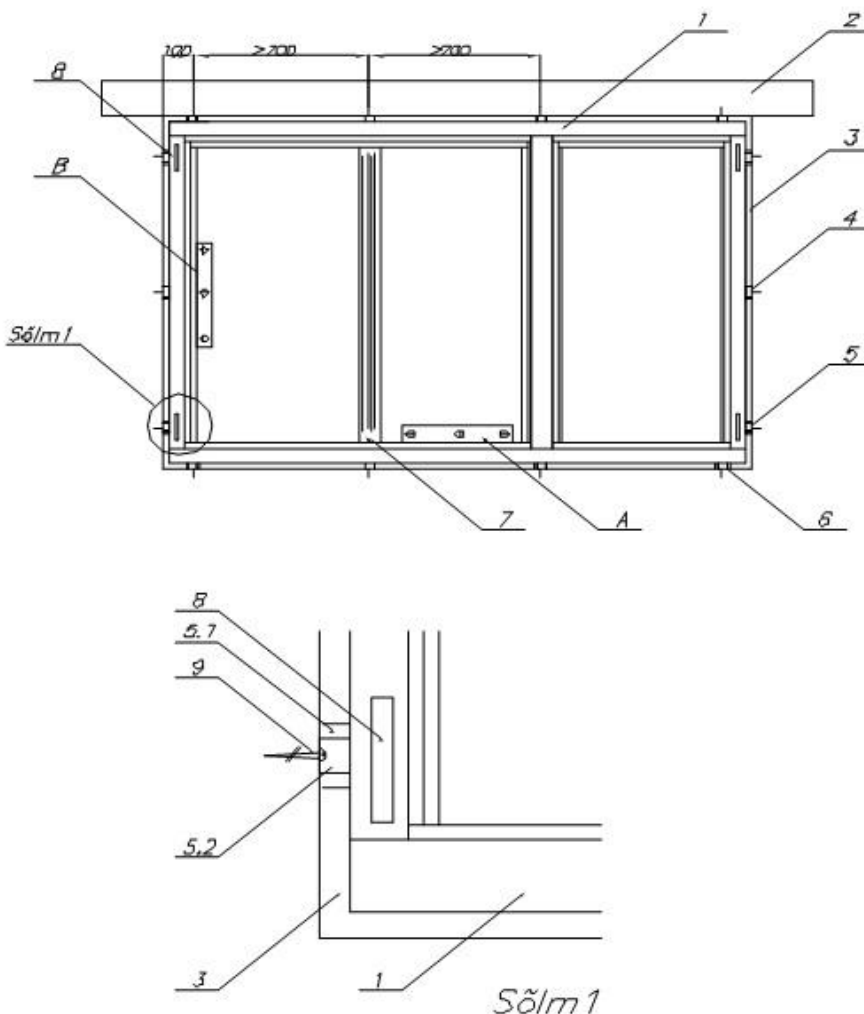

1. Window sash
2. Lintel or monolithic concrete.
3. Gap for filling material (between 5-20 mm between the lintel and upper horizontal).
4. Wall anchors.
5. Wall anchors and wedges for leveling the verticals of the sash.
6. Wall anchors and wedges for leveling the window.
7. Intermediate support, which is placed over a wide window to prevent the sashes from bending when the gap is being filled with expanding material.
8. Frame hinges.
9. Screws (wall plugs) for fastening the sashes to the wall using wall anchors.

Warranties.

The windows of OÜ SeiCom have:

- 2 year warranty on quality and construction of factory finished windows and wood.
- 5 year warranty against condensation inside the glazing unit.

Products are covered by the warranty provided that the installation guide and user manual of the company products have been followed. The company undertakes to repair or replace, at its choice, all the products of the company which are defective in materials or defective in production within 24 months of receipt of the products.

The company warranty does not apply if:

- the customer has not fully paid for the products;
- the customer has made or attempted to make modifications to the products if this has not been accepted by the company;
- the customer has not followed the installation guide or user manual or has otherwise stored the products incorrectly; the company has not been notified of noncompliance within two (2) weeks of receipt of the goods.

Window Storage Conditions:

- Windows may only be installed in wall openings after the roof has been installed and the floor has been cast (the relative humidity should not exceed 65%). If the indoor humidity is higher than allowed in the construction phase and the excess humidity begins to condense on the windows, the rooms should be ventilated as required or the humidity collector should be used.
 - Only transport windows in a vertical position.
 - Protect windows from shocks and scratches during transportation.
 - Avoid getting rainwater, pouring water and condensation water on the wooden parts of the window.
 - Close or lock the windows when there is a risk of draft wind. Do not allow airflows to "throw" the window!
 - During plastering and interior finishing, cover the windows with film to prevent dyes, plaster dust, etc. contact with glass or other window surfaces.
- NB! If windows are covered with film, adequate ventilation of the wooden parts must be ensured.
- If protective tape is used to protect the wooden parts, make sure that the protective tape is removed immediately after completion of work.
 - By meeting these requirements, the window will retain its durability and high-quality appearance even after long-term use.